

# POLYGRIP

COMBINING SYSTEMATICALLY

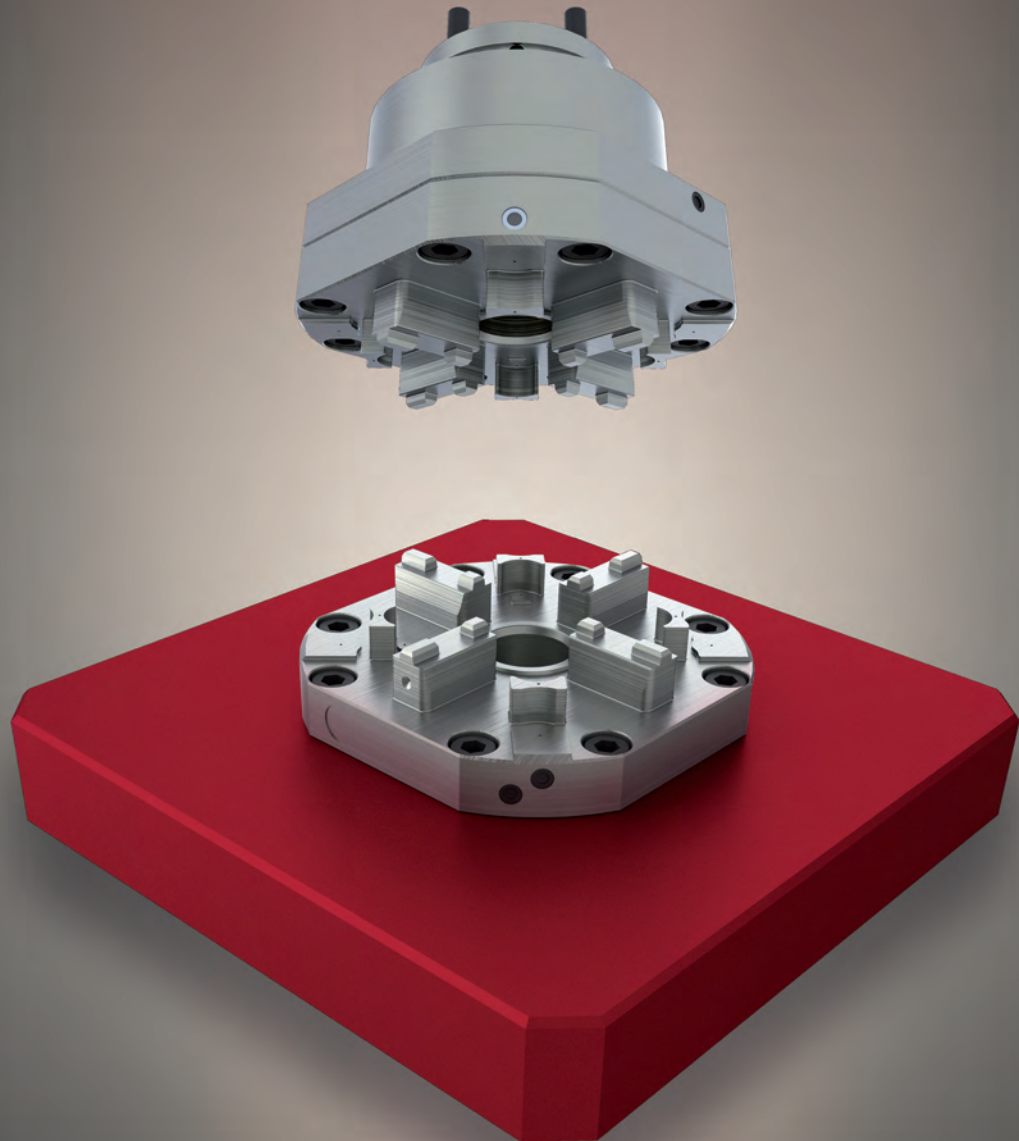

## The Poly-Grip System

The combined  
elektrode palletizing system



# One-of-a-kind

EROWA

Poly-Grip

Power-Grip

System 3R

# Poly-Grip. A bright bridging.

one-of-a-kind  
worldwide

## Once: Dependence.

The more complicated a workpiece is the more special are the demands concerning it's production. Special solutions often require special tools. Some approach ends in running the technical guantlet. Sovereign territories carry their name rightly. Customers sometimes absolutely depend on one system supplier. Some approach ends in absolute dependency.

## Now: Independence.

*Poly-Grip* thinks in a different way. *Poly-Grip* practizes teamwork where others try to encapsulate. *Poly-Grip* allows to find new ways for production right through strictly protected technical territories. *Poly-Grip* brings together the technical world of the two biggest providers of the market without betraying own principals. Due to *Poly-Grip* an uncritical relentless technical pursuit finds it's end.

*Poly-Grip offers a new freedom of choice.*

**POLYGRIP**



*Freedom to act –  
quality included*

## *Poly-Grip ... in the pallet*

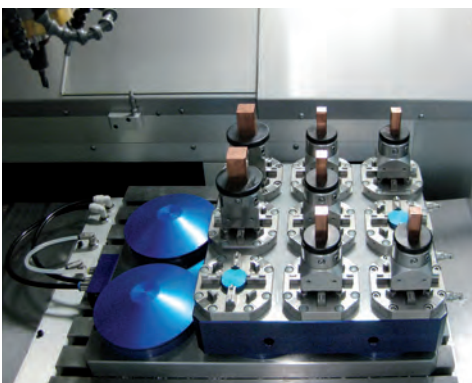

*Poly-Grip x9-pallet on Rödgers*

## *Poly-Grip ... in the sleeve*



*Poly-Grip sleeve-sided*



# Freedom of choice



# Poly-Grip.

## A brilliant system for machine table and sleeve.

### Setting the course your way.

With *Poly-Grip* your production can act with less operation expense and more flexibility. The technology of *Poly-Grip* enables the interchange of different systems of clamping elements. It's no odds whether the pallet or the electrode holder comes from EROWA or from System 3R:

*Poly-Grip manages it!*

### Quality you can rely on at any time.

*Poly-Grip* clamps with a power of up to 13.000 N. *Poly-Grip* is made out of high quality steel. The whole system is stainless and the fatigue of material vanishingly small. All components are virtually non-wearing.

**POLYGRIP**



*One way –  
a lot of directions.*

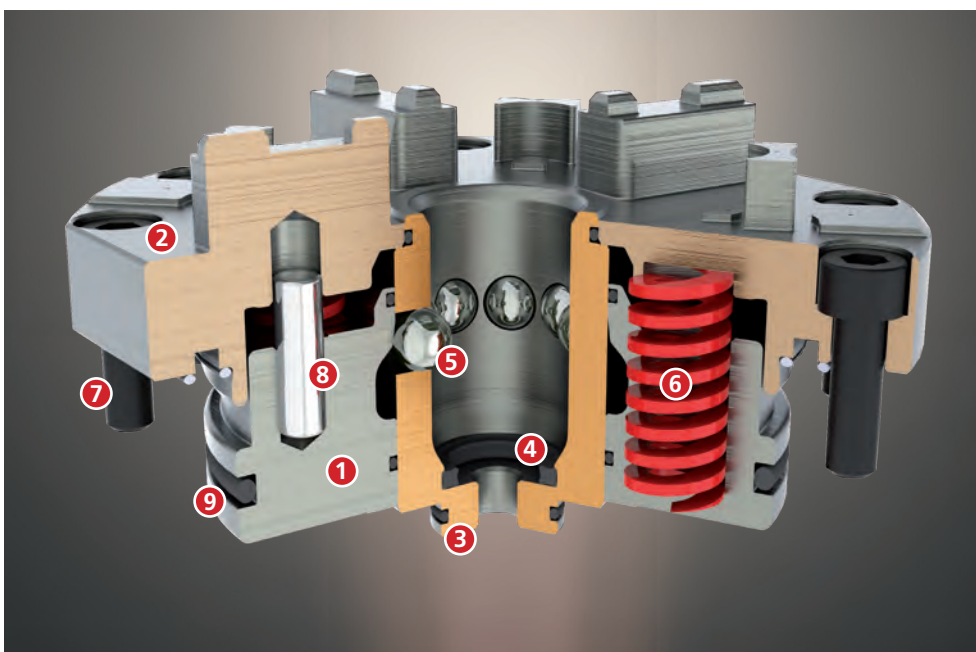

- 1 Piston
- 2 Centering surface
- 3 Ball cage
- 4 Flushing seal
- 5 Ball
- 6 Pressure spring
- 7 Screw
- 8 Locking piston
- 9 Sealing ring

# Security



# Poly-Grip.

A masterstroke in many directions – at the same time.

## Poly-Grip.

The investment boomerang.

A chuck normally – depending on duty – gets maintained or repaired triennial. That partly causes costs in a four-digit figure – the costs for service technician and machine shutdown not even included.

*Poly-Grip* makes the difference. *Poly-Grip* is much more than a clamping system – it's a combination system. Together with third-party technology it runs without problems and nearly without maintenance. For a machine table and a sleeve *Poly-Grip* is a brilliant system which offers a lot of installation possibilities.

*Poly-Grip* weeds the rampant forest of adapters. The possibility to combine tools of different system-producers saves a lot of money. Your production runs as usual but with less parts and more precise and cost-efficient than before.

Your competitiveness increases in the same dimension as your freedom of production – better quality included.

*Poly-Grip. One-of-a-kind. Worldwide.*

**POLYGRIP**



*Bringing quickly back  
your investment*



# POLYGRIP

COMBINING SYSTEMATICALLY

Please also note the full range of our clamping systems:

**GENIUSGRIP**  
CLAMPING SYSTEMATICALLY

The zero-point clamping system for large-scale machining centres for milling and turning section

**POWERGRIP**  
PALLETIZING SYSTEMATICALLY

The consistent zero-point palletizing system for all processing operations

**MICROGRIP**  
PRODUCING SYSTEMATICALLY

The modular mini zero-point palletizing system for work pieces and gripper technology

**SMARTGRIP**  
WIRE ERODING - SYSTEMATICALLY

The modular zero-point palletizing system for wire EDM-ing

**POLYGRIP**  
COMBINING SYSTEMATICALLY

The combined electrode palletizing system

**DEFOGRIP**  
PRODUCING SYSTEMATICALLY

The workpiece clamping system

**ROTOGRIP**  
PRODUCING SYSTEMATICALLY

The palletizing system for rotative machining

Headquarters • worldwide distribution

**PAROTEC**  
spanntechnik • robotik • engineering

PAROTEC AG  
Lerchentalstraße 29  
CH-9016 St. Gallen  
Tel.: +41 (0)71 394 10 00  
info@parotec.ch  
www.parotec.ch

Distribution Germany and Benelux

**PARTOOL**  
Palettieren • Automatisieren • Rationalisieren

PARTOOL GmbH & Co. KG  
Edisonstraße 19  
D-90431 Nürnberg  
Tel.: +49 911 65 65 89- 0  
info@partool.de  
www.partool.de