

GENIUSGRIP

CLAMPING SYSTEMATICALLY

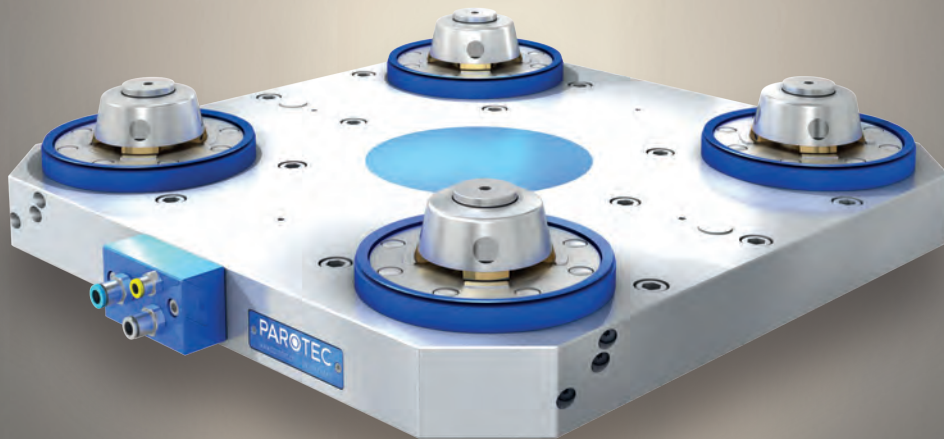
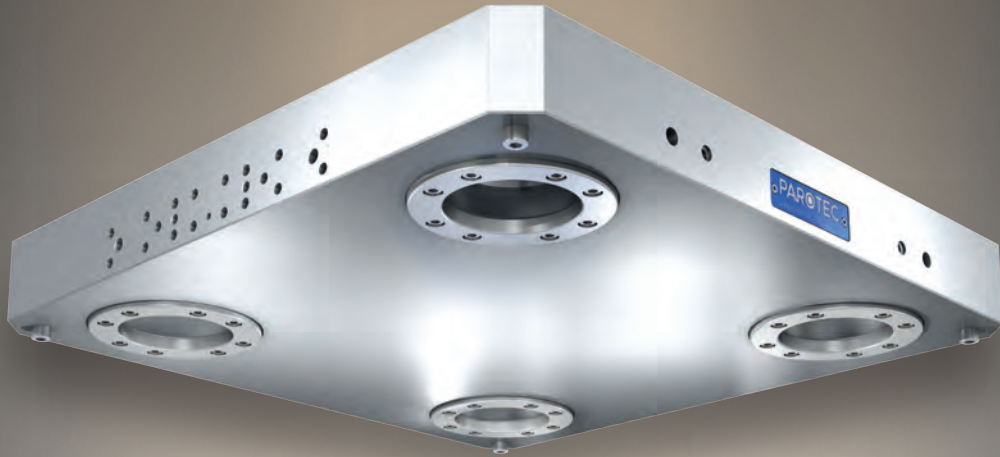

The Genius-Grip System

The zero point clamping system for large-scale machining centres
for milling and turning section



The inventor

created by

PAROTEC
spanntechnik · robotik · engineering

PAROTEC AG
Lerchentalstraße 29
CH-9016 St. Gallen
Tel.: +41 (0)71 394 10 00
info@parotec.ch

PAROTEC has more than 35 years of experience in the field of high precision workpiece clamping.

One of the technical top performers is the development of the zero point palletizing system "Power-Grip". Many notable clients worldwide have trusted the process reliability of this technology for years.



Distribution Germany and Benelux

PARTOOL
Palettieren · Automatisieren · Rationalisieren

PARTOOL GmbH & Co. KG
Edisonstraße 19
D-90431 Nürnberg
Tel.: +49 (0)911 65 65 89- 0
info@partool.de

The company PARTOOL is distributor of the manufacturer PAROTEC for Germany and Benelux.

At the technology and sales center in Nuremberg, you can personally convince yourself of the performance and the precision of the Parotec products at any time.



The zero point clamping system for large-scale machine centres for milling and turning section.

What is a zero point palletizing system?

A **zero point palletizing system** allows you to clamp and position work pieces, clamping media and fixtures **quickly and precisely**.

The standardised interfaces **drastically reduce set-up time, particularly for single workpieces and small batch production, thereby increasing effective machine uptime and productivity.**

Content

GENIUSGRIP



Overview of 10 advantages	
1. The system / machine runtime	Page 04/05
2. Centering units / clamping sleeves	Page 06/07
3. System unlocked / system locked	Page 08/09
4. Loading	Page 10/11
5. Tolerance-free centering	Page 10/11
6. Thermal expansion	Page 12/13
7. Process safety	Page 12/13
8. Modularity	Page 14/15
9. Maintenance	Page 14/15
10. Consistency	Page 16/17
Tensioning force and stability	Page 18/19

1. The system

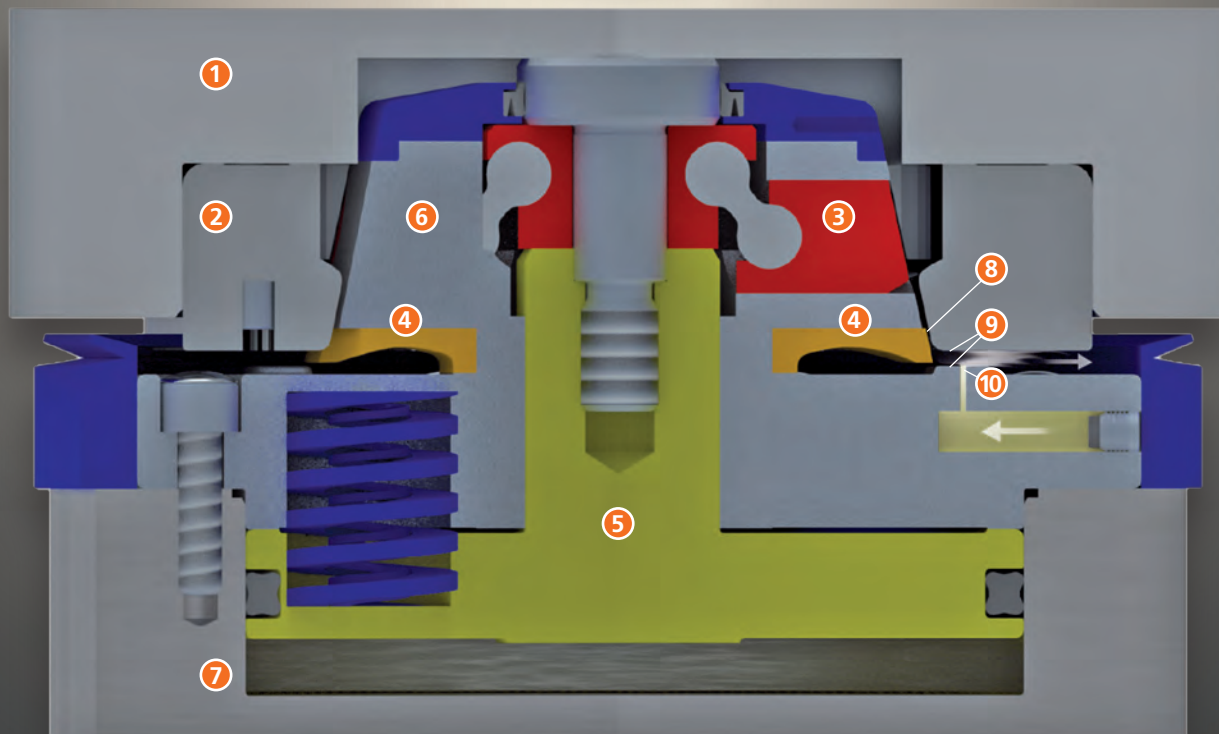
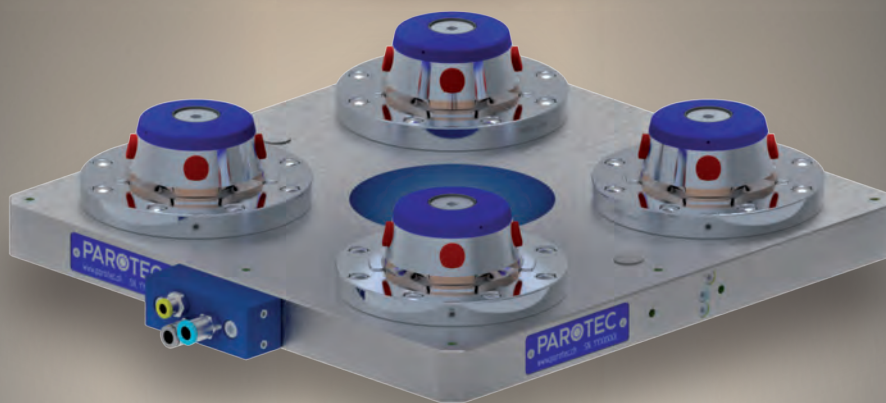
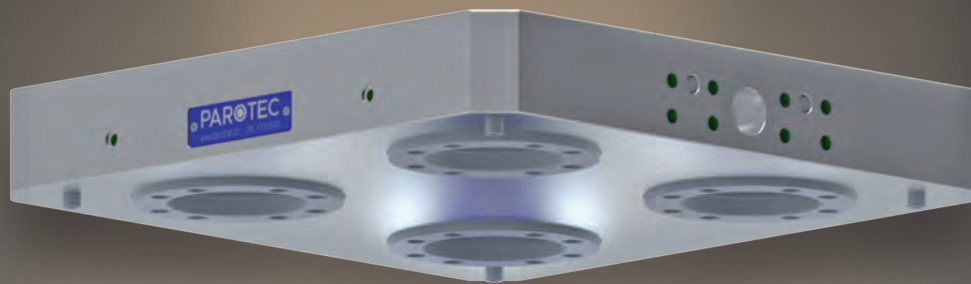

- | | |
|---------------------------------|------------------------------------|
| ① Pallet | ⑥ Clamping bolt cage |
| ② Centering and clamping sleeve | ⑦ Pallet carrier |
| ③ Clamping mechanism | ⑧ XY-reference surfaces |
| ④ Centering spring lugs | ⑨ Z-reference surface |
| ⑤ Piston | ⑩ Nozzles for Z-reference cleaning |

The constant zero point clamping system for the heavy weight classes.

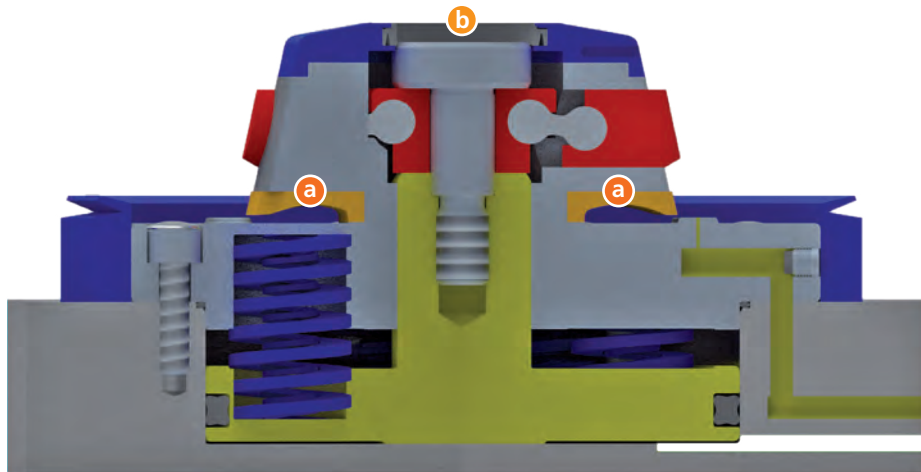

Disadvantage of classic clamping systems

Many classic clamping systems work with large rigid clamping surfaces without plane support (SK-principle).

The result: Measuring, clamping and aligning the workpieces is done in the machine.

The machine stands still.

Advantage of Genius-Grip

The clamping system Genius-Grip clamps with an axially resilient centering device **a** and with plan support **b** (HSK-principle).

The result: Measuring, clamping and aligning the workpieces is done outside the machine. **The machine is running.**

Up to 45% more efficiency of your existing machine outfit.

GENIUSGRIP



*Many say: You can't change that.
This is what our routine looks like:*

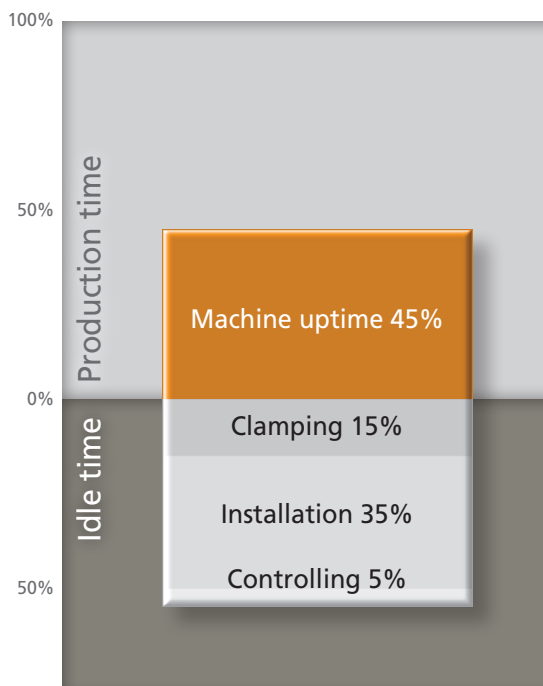

*We say: Everything changes with Power-Grip.
And this is what your Genius-Grip future looks like:*

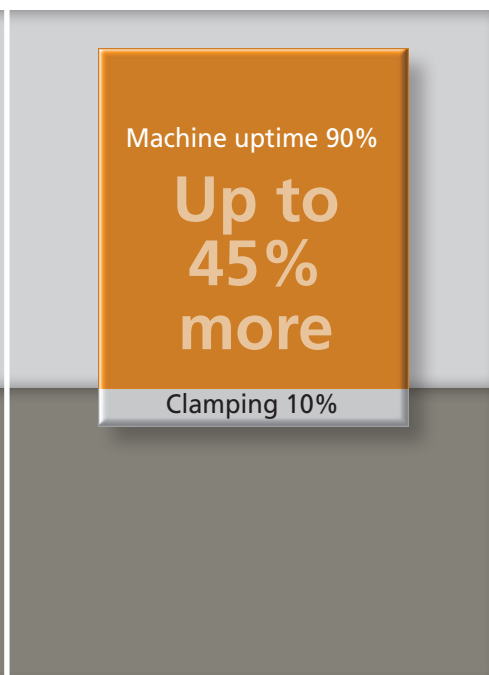

Genius-Grip allows measuring and alignment outside the machine

With the right palletizing you can clamp within seconds

2. Centering unit

One-of-a-kind
worldwide

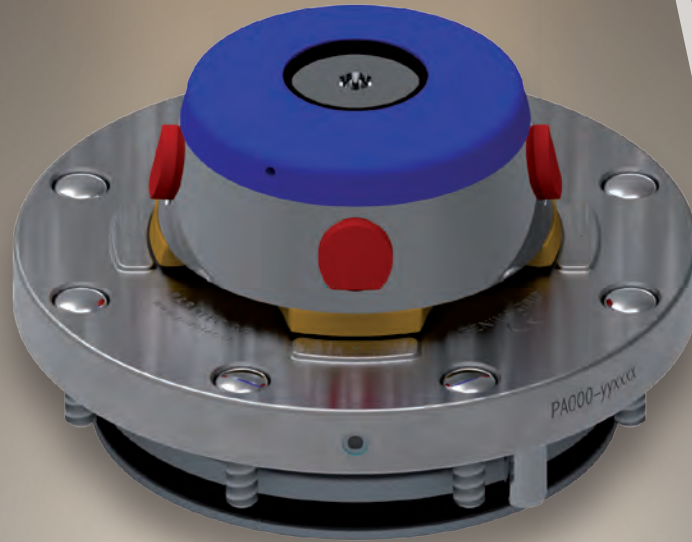

Centering unit with axial spring centering and face support including Z-reference cleaning.

Centering clamping sleeve

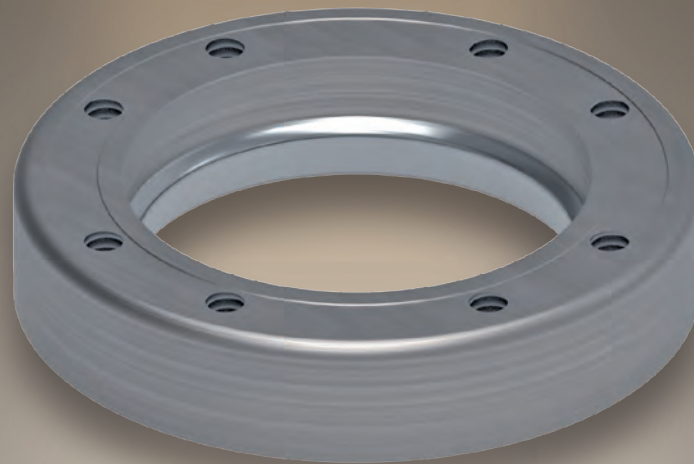

The Genius-Grip centering and clamping sleeves are hardened and corrosion resistant.

The installation dimensions of the Genius-Grip centering unit

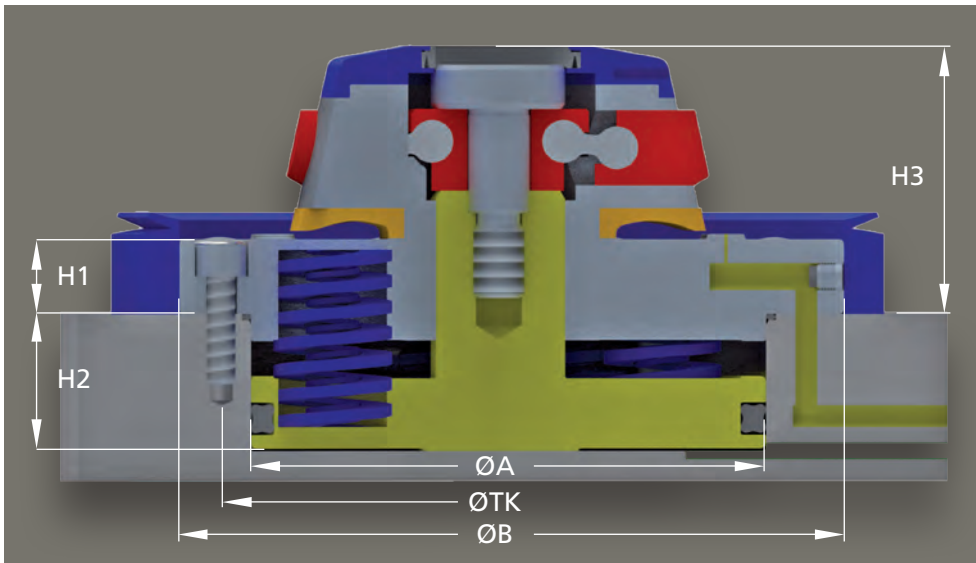

H1	H2	H3	Ø A	Ø TK	Ø B
15 $+0,005$ $-0,000$	25,5/31	50	100 $+0,02$ $+0,005$	112	129

The installation dimensions of the Genius-Grip centering and clamping sleeve.

GENIUSGRIP



*Clamping technology for
everyday production*

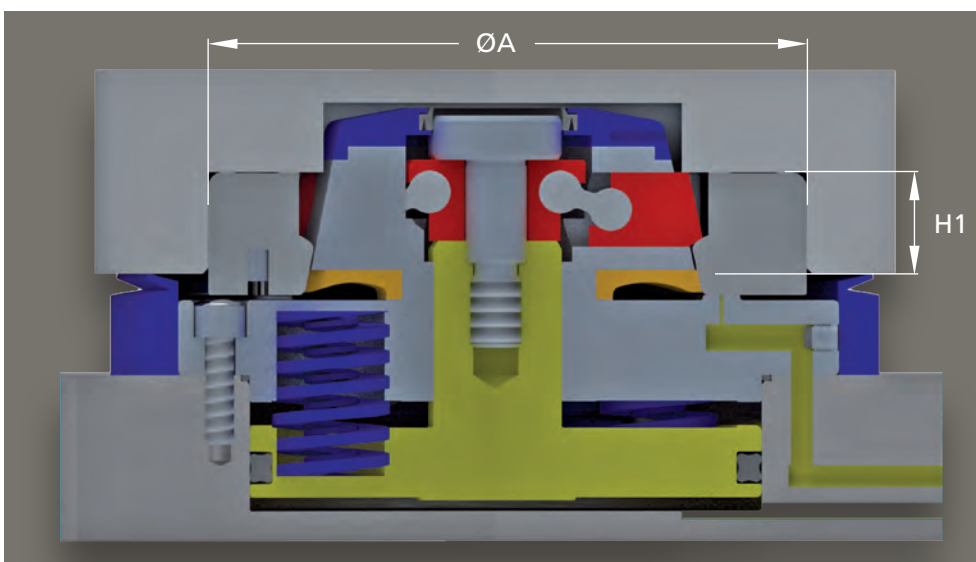

H1	Ø A
23 $+0,01$ $+0,0$	117 $-0,0$ $-0,02$

3. System unlocked

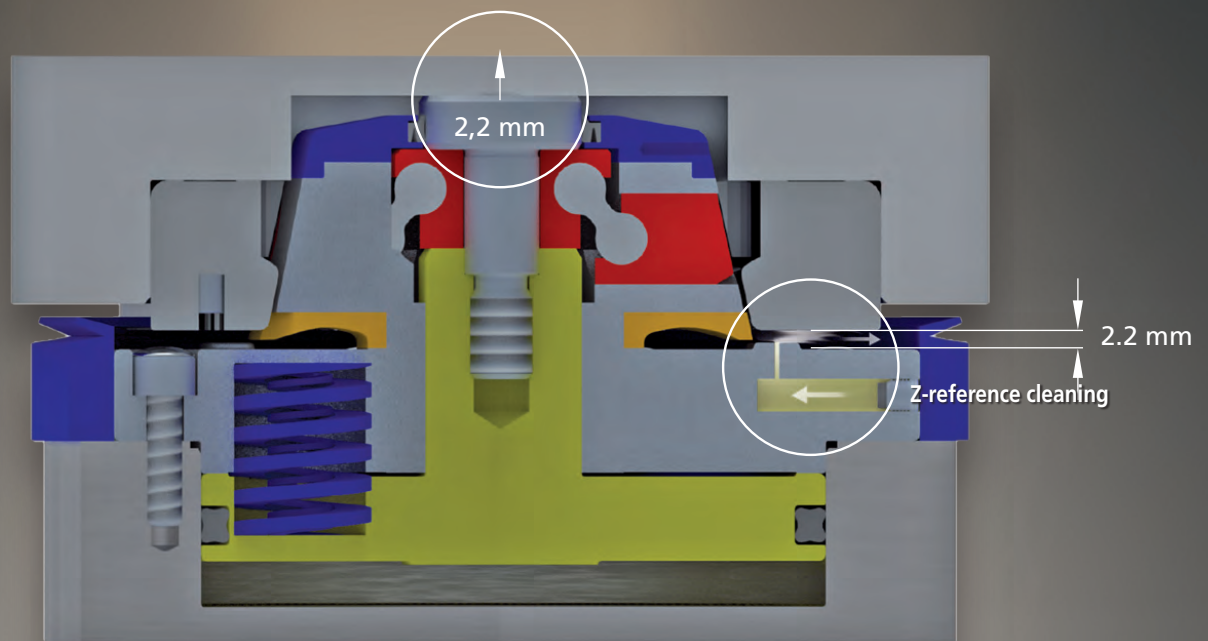

The pallet is lifted by 2.2 mm.
Reference surfaces are not in contact.

The reference surfaces are free and
permanently cleaned by air flow.

System locked

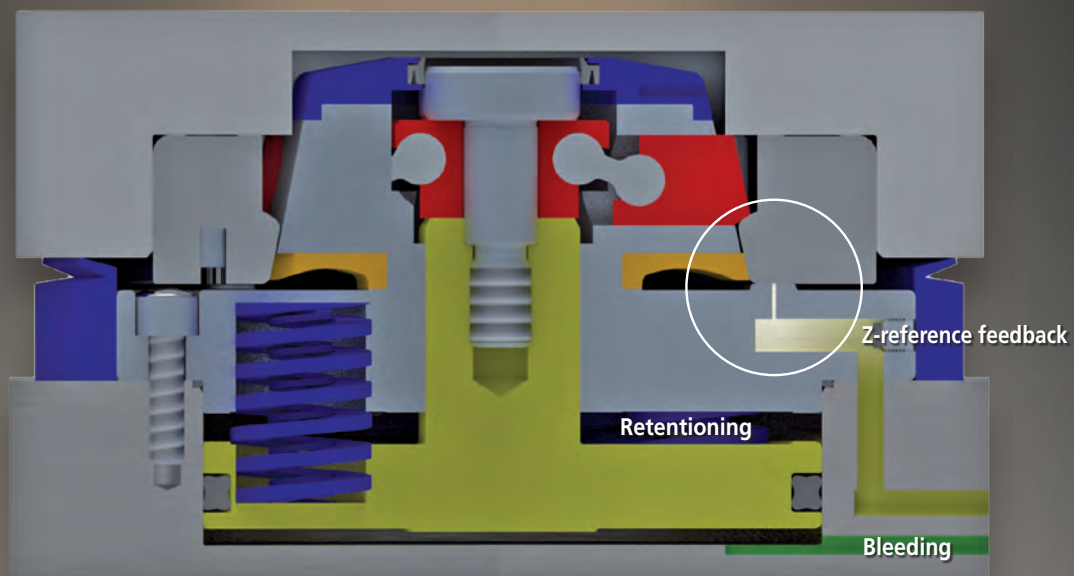

The centering is tolerance free with axially
resilient centering lips (HSK-function).

Z-reference feedback is possible by
measuring dynamic pressure.

Genius-Grip – clamping with integrated self-protection mechanism.

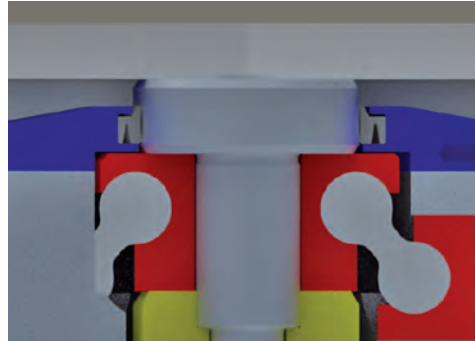
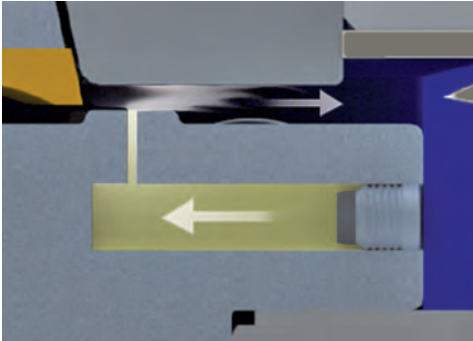

With Genius-Grip you choose doubly integrated safety.

1. With a large pre-centring via the external clamping bolt cage a damage to reference surfaces is excluded.

2. The lift-off function raises the pallets by 2.2 mm. Reference surfaces only come in contact during the clamping process.

Genius-Grip. Precision always and everywhere.

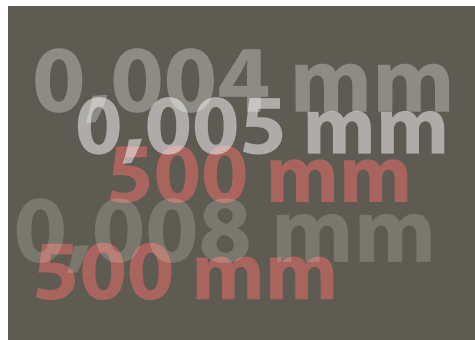
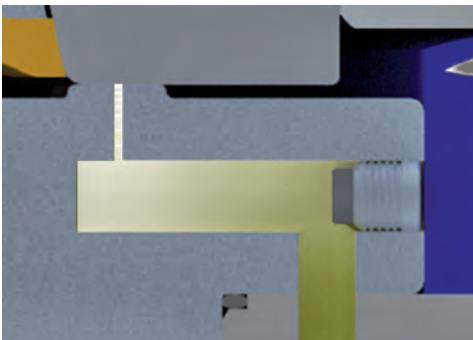

GENIUSGRIP



*Thoughtful
down to the last detail*

With Genius-Grip you choose multiple integrated safety.

Repeatability:	0,004 mm / 500 mm
System accuracy:	< 0,008 mm / 500 mm
Runout accuracy:	< 0,008 mm / Ø 500 mm
Clamping to the system centre:	0,004 mm / 500 mm

4. Loading

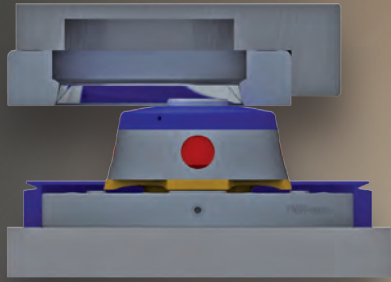

Large lateral offset?
No problem!

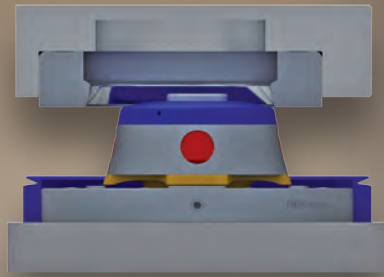

By the large pre-centring
the pallet always finds its place!

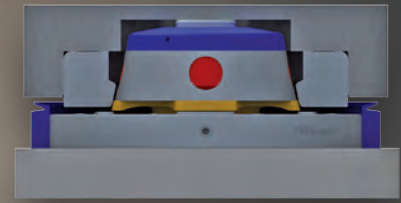

When loosened, the pallets are
lifted by 2.2 mm

Even tilted pallets find their
destination safely during
feeding.

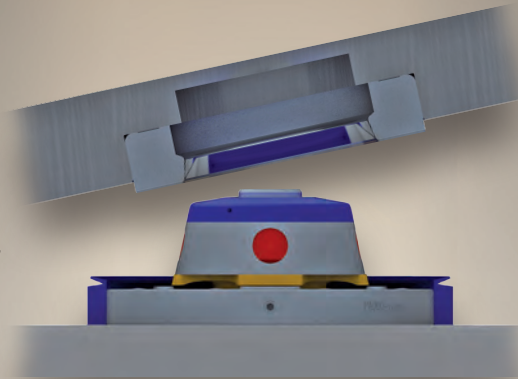

**One-of-a-kind
worldwide**

5. Tolerance-free centering

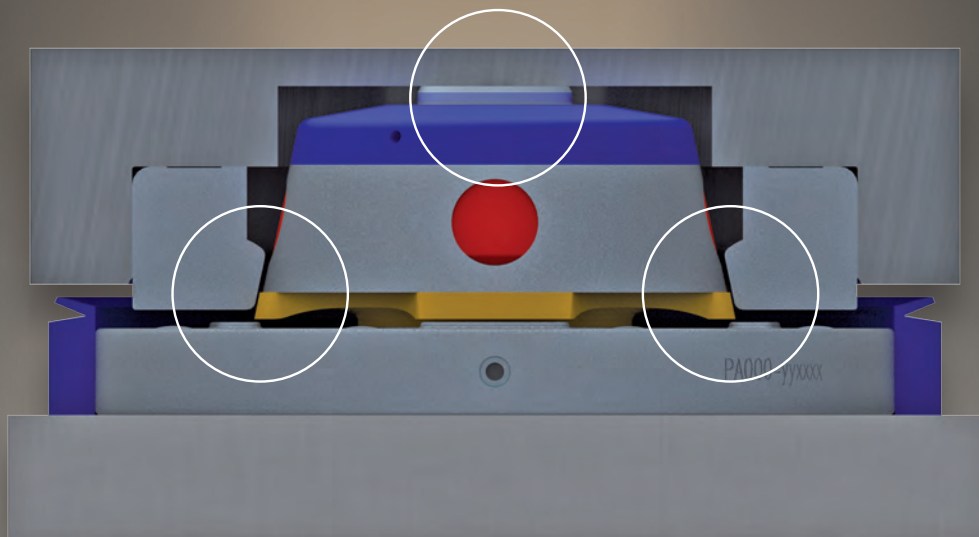

Genius-Grip. Feeding without accident risk.

Possible backlash with conical chucking bolts

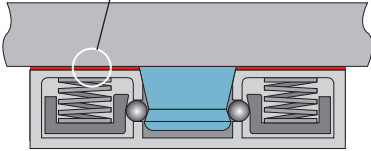

Possible backlash with conical chucking bolts

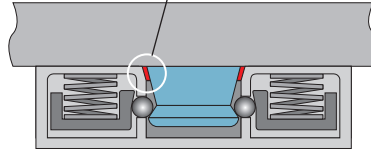

Possible backlash with cylindrical chucking bolts

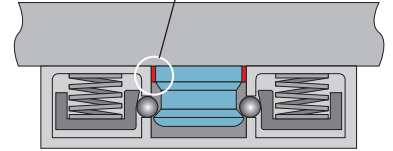

Disadvantage of classical clamping systems.

Many classical clamping systems have rigid, protruding chucking bolts (SK-principle). There is always a risk of damaging Z-reference surfaces during loading and unloading. By placing pallets on the chucking bolts they can easily lose their zero point. Compensation of thermal changes is not possible. The result: permanent zero point displacements.

Genius-Grip. Far ahead for sure.

GENIUSGRIP



*One-of-a-kind
worldwide*

Advantages of Genius-Grip.

1. With a large pre-centring via the clamping bolt cage, damage to whatever reference surfaces is excluded during loading and unloading.
2. Genius-Grip positions tolerance-free thanks to axially resilient centring lips (HSK-principle). The lift-off function lifts the pallets by 2.2 mm. Reference surfaces only come into contact during the clamping process.
3. Thermal changes are compensated by the Genius-Grip-System without zero point displacements.
4. There is no loss of reference when the pallets are parked or stored.
5. Even tilted or diagonally fed pallets find their destination safely with Genius-Grip.

No one else in the world offers you these advantages.

6. Thermal expansion

Classical clamping systems

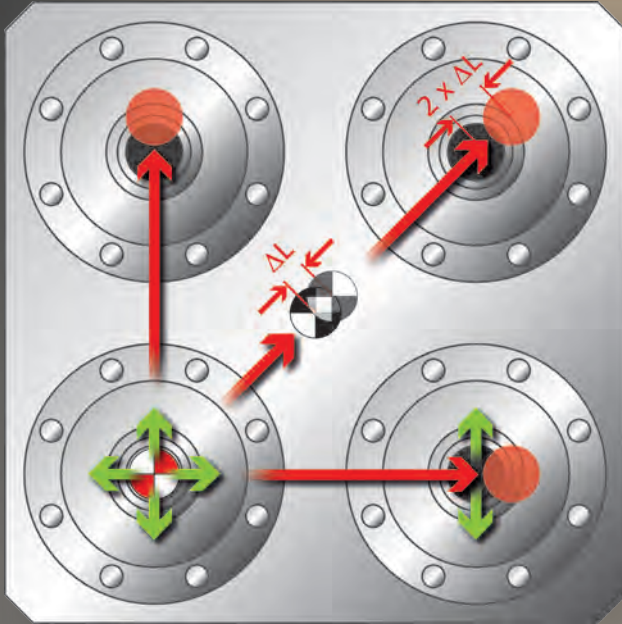

0° positioning

Our technique

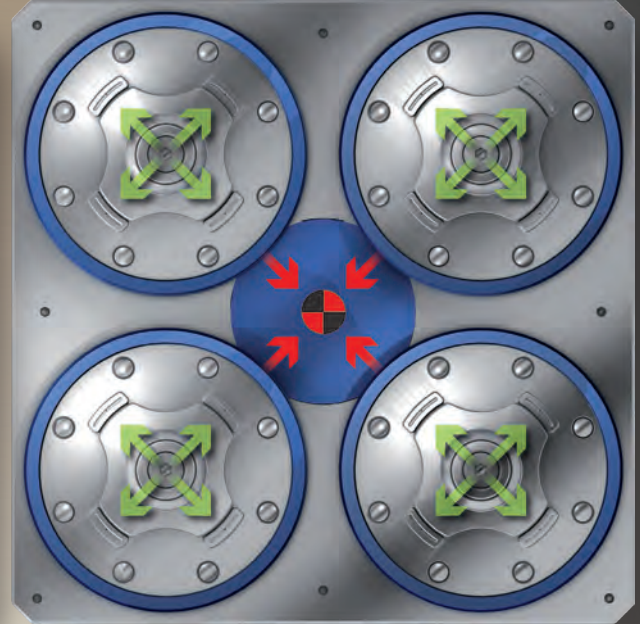

0° positioning

7. Process safety

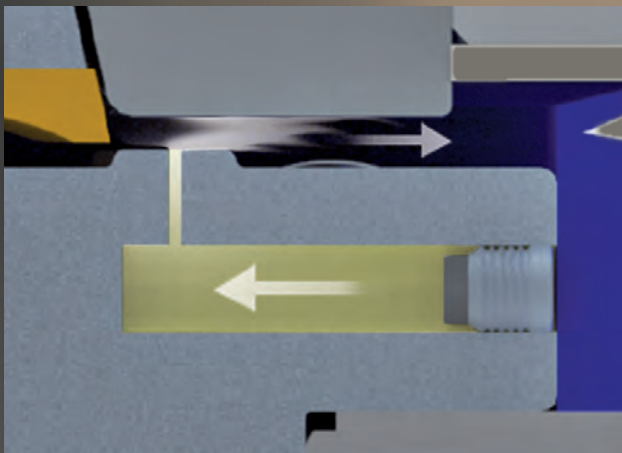

Permanent Z-reference cleaning by air flow in unlocked state

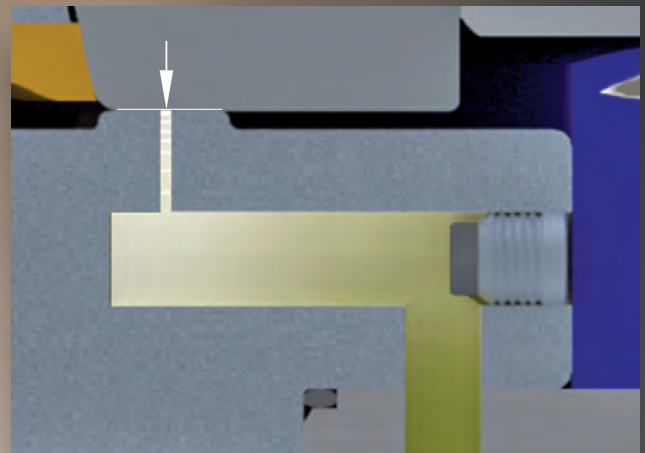

Z-reference feedback in locked state.

Genius-Grip.

The system centre always in focus.



Disadvantages of classic clamping systems.

With classic clamping systems, the centering is floating. The zero point of the system is off-centre. The workpiece zero point therefore shifts with the slightest thermal fluctuation. This has a very unfavourable effect on 5-axis and mill-turn operations.

Genius-Grip.

Process reliability brought to the point.

GENIUSGRIP



Accuracy with system

Advantages of Genius-Grip.

1. Genius-Grip centers backlash-free via axially resilient centering lips (HSK-principle).
2. Genius-Grip automatically compensates for thermal warping. The zero point remains unchanged in the centre of the system.
3. The island-shaped Z-reference surfaces are automatically cleaned.
4. High process reliability during automation due to system control via z-references.
5. No dirt-prone internal clamping mechanism.
6. Doublesided hardened and rust-free reference surfaces both in the pallet and the clamping system.

Repeatability:

0,004 mm / 500 mm

System accuracy:

< 0,008 mm / 500 mm

Runout accuracy:

< 0,008 mm / Ø 500 mm

Clamping to the system centre:

0,004 mm / 500 mm

The result:

Genius-Grip delivers a very high precision, especially in 5-axis and mill-turn operations.

8. Modularity

Genius-Grip pallet carrier on machine table

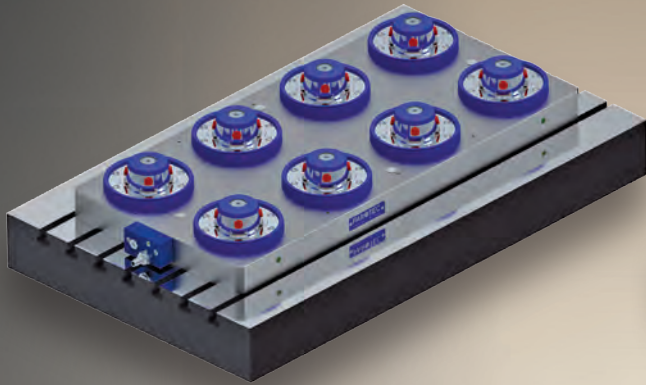

Genius-Grip pallet carrier on machine table with two pallets x4

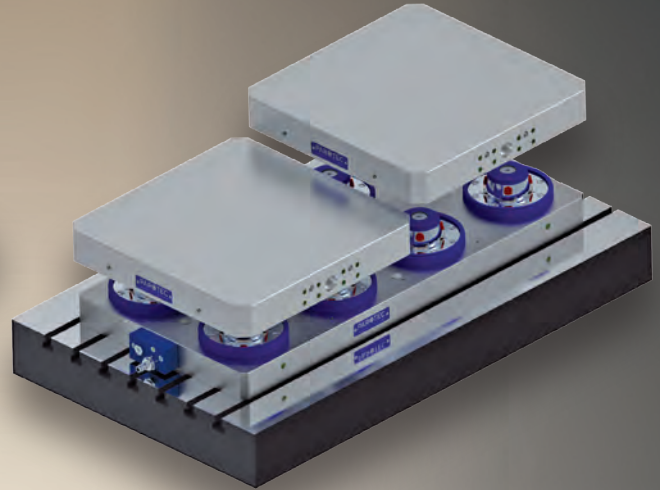

9. Maintenance

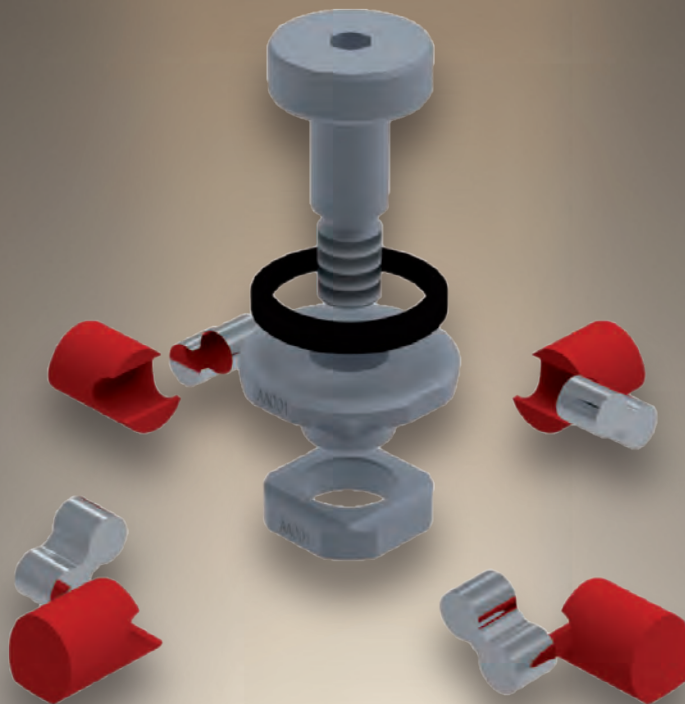

Genius-Grip. The system with adaptability.

Example: Genius-Grip pallet x8

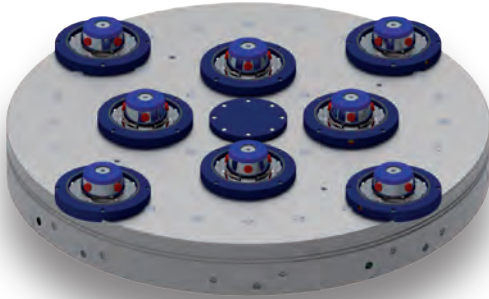

Example: Genius-Grip pallet x12

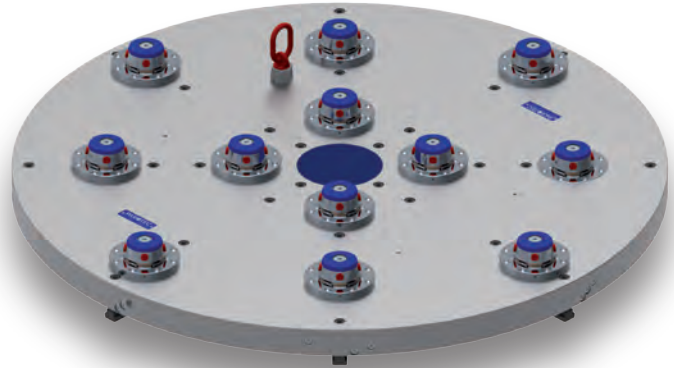

Advantages of Genius-Grip.

1. Genius-Grip clamping systems are available in different sizes and designs.
2. Genius-Grip pallets can be combined with each other (see illustration on the left).
3. Genius-Grip can be adapted to machine and workpiece sizes.

Unneeded centering units are covered with the chip guard to protect them from chips

Genius-Grip. Maintenance with minimum effort.

Advantages of Genius-Grip.

1. Cleaning and maintenance of the clamping system is possible from the outside without loss of zero point and disassembly of the clamping system.
2. No expensive specialist personnel is required for cleaning and maintenance. The work can be carried out in the shortest possible time by the operator of the machine.
3. Genius-Grip is completely rust-resistant – thus no corrosion and minimum wear.
4. Machine downtime due to contamination or wear is almost impossible.

GENIUSGRIP



*Modularity and functionality
down to the last detail*

10. Consistency

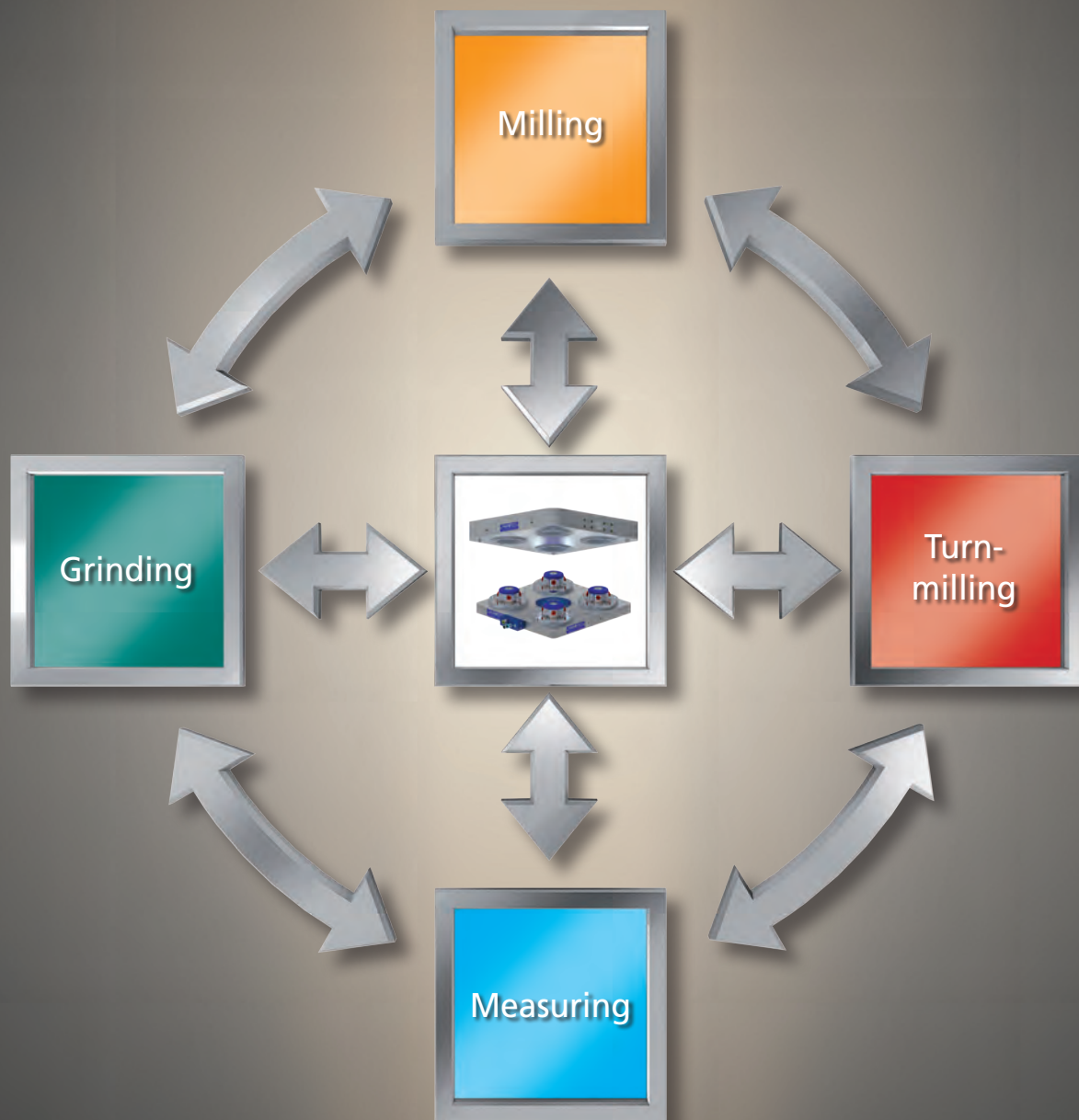

Genius-Grip. In the service of your production.

Disadvantages of classic clamping systems.

1. Various and often incompatible systems for different manufacturing and machining processes.
2. Partly fixed system sizes.

Genius-Grip. Consistency that one wishes for.

GENIUSGRIP



*Workpiece and production
optimally under control*

Advantages of Genius-Grip.

1. Various system sizes and stich dimensions offer maximum modularity.
2. Genius-Grip adapts easily to workpiece sizes and to existing and new machines.
3. Optimum consistency through a single always compatible system for all manufacturing and machining processes such as:
 - 3- or 5-axis milling
 - Measuring
 - Grinding
 - Milling- turning machining

Tensioning force and stability

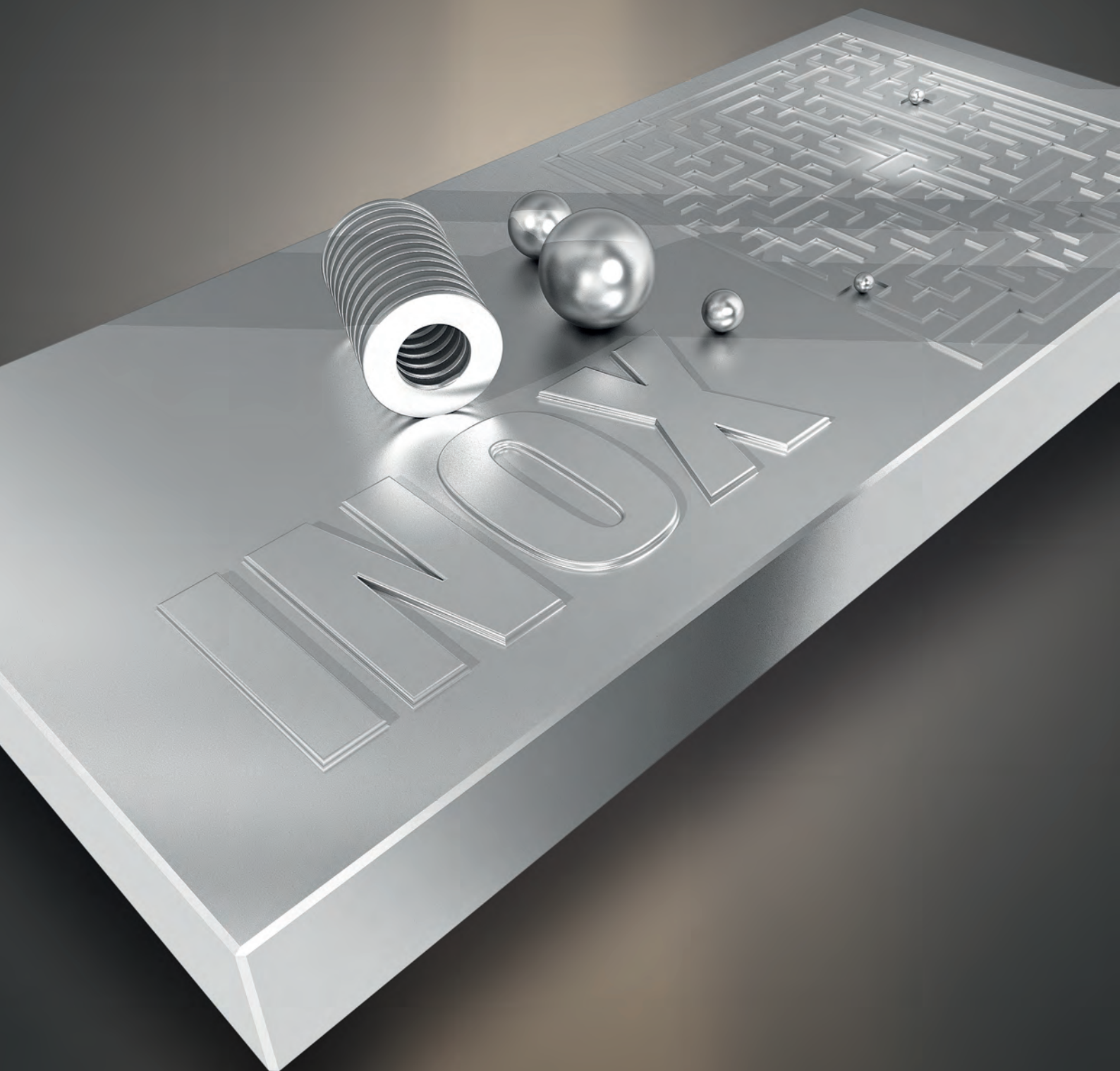

Genius-Grip.

Numbers speak for themselves.

Genius-Grip	Release pressure	Retraction force	Tensioning force
Centering unit hydraulic	60 – 5 / +15 bar	30.000 N	80.000 N

Hydraulic volume piston	CU (pallet) unlocked	CU (with pallet) clamped	CU (without pallet) clamped
	0.283 l	from 0.101 l to 0.079 l	0.016 l

1. Mechanical tensioning by spring assembly with self-locking toggle-lock
2. Optimum retraction force for very high holding force
3. Highest stability and accuracy by tolerance-free centering (HSK-principle)
4. No vibrations and resonances

GENIUSGRIP



A system that delivers what it promises

Yield point screw 8.8	Cheese head screw M8 (8.8)	Max. yield point per centering unit
$Re = 8 \times 8 \times 10 \text{ N/mm}^2 = 640 \text{ N/mm}^2$	Core diameter thread 6.466 mm	$Re \times F \times A$
Tensile strength of screw 8.8	$F = \text{Cross sectional area (PL x r}^2) 32.837 \text{ mm}^2$	$640 \text{ N/mm}^2 \times 32.837 \text{ N/mm}^2 \times 8 = 168'125 \text{ N}$
$Rm = 8 \times 100 \text{ N/mm}^2 = 800 \text{ N/mm}^2$	$A = \text{Number of cheese head screws M8} = \times 8$	

Pressure force cylinder	
P Hydraulic pressure	60 bar = 600 N/cm ²
Piston	10 cm
F_k Piston surface (Pl x r ²)	78.54 cm ²
Piston force (P x F _k)	47'124 N

The result shows a more than 3-fold safety factor

GENIUSGRIP

CLAMPING SYSTEMATICALLY

Please also note the full range of our clamping systems:

GENIUSGRIP
CLAMPING SYSTEMATICALLY

The zero point clamping system for large-scale machining centres for milling and turning section

POWERGRIP
PALLETIZING SYSTEMATICALLY

The consistent zero point palletizing system for all processing operations

MICROGRIP
PRODUCING SYSTEMATICALLY

The modular mini zero point palletizing system for work pieces and gripper technology

SMARTGRIP
WIRE ERODING - SYSTEMATICALLY

The modular zero point palletizing system for wire EDM-ing

POLYGRIP
COMBINING SYSTEMATICALLY

The combined electrode palletizing system

DEFOGRIP
PRODUCING SYSTEMATICALLY

The workpiece clamping system

ROTOGRIP
PRODUCING SYSTEMATICALLY

The palletizing system for rotative machining

Headquarters • worldwide distribution

PAROTEC
spanntechnik • robotik • engineering

PAROTEC AG
Lerchentalstraße 29
CH-9016 St. Gallen
Tel.: +41 (0)71 394 10 00
info@parotec.ch
www.parotec.ch



Distribution Germany and Benelux

PARTOOL
Palettieren • Automatisieren • Rationalisieren

PARTOOL GmbH & Co. KG
Edisonstraße 19
D-90431 Nürnberg
Tel.: +49 (0)911 65 65 89- 0
info@partool.de
www.partool.de